



GREASE METER MKIII

0102525 ISO-G1/8

0102525-1 M10x1

0102525-2 NPT1/8

USER'S MANUAL
INSTRUKTIONER
BEDIENUNGSANLEITUNG
INSTRUCTIONS

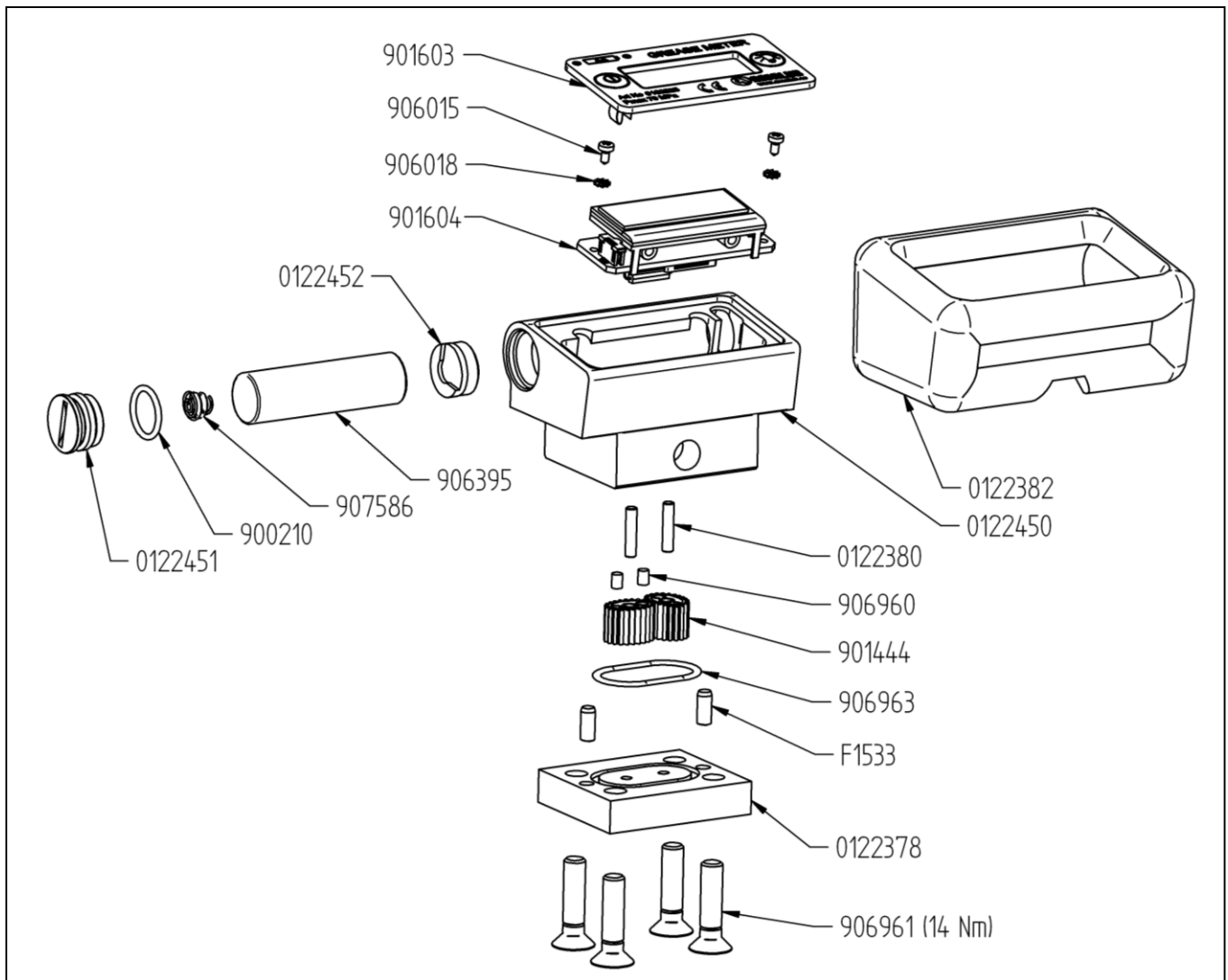

SPARE PARTS
RESERVDELAR
ERSATZTEILE
PIÈCES DE RECHANGE

Art. No.	Designation	Benämning	Bezeichnung	Désignation
0122378	Cover	Lock	Abdeckung	Couvercle
0122380	Pin	Pinne	Stift	Goupille
0122382	Rubber cover	Gummiskydd	Gummischutz	Protection en caoutchouc
0122450	House ISO-G1/8	Hus ISO-G1/8	Gehäuse ISO-G1/8	Logement ISO-G1/8
0122450-1	House M10x1	Hus M10x1	Gehäuse M10x1	Logement M10x1
0122450-2	House NPT 1/8	Hus NPT 1/8	Gehäuse NPT 1/8	Logement NPT 1/8
0122451	Battery cover	Batterilock	Batterieabdeckung	Couvercle de batterie
0122452	Battery spacer	Batteridistans	Batterie distanz	Écarteur de batterie
900210	O-ring 11.1x1.6	O-ring 11,1x1,6	O-Ring 11,1x1,6	Joint torique 11,1x1,6
901444	Oval gear	Ovalkugghjul	Ovales Zahnrad	Roue à engrenages ovale
901603	Keyboard	Tangentbord	Tastatur	Clavier
901604	Circuit board	Kretskort	Leiterplatte	Carte de circuits
906015	Screw 2.2x4.5	Skruv 2,2x4,5	Schraube 2,2x4,5	Vis 2,2x4,5
906018	Washer 2.2x4.5	Bricka 2,2x4,5	U.-Scheibe 2,2x4,5	Rondelle 2,2x4,5
906395	Battery AA	Batteri AA	Batterie AA	Batterie AA
906960	Magnet	Magnet	Magnet	Aimant
906961	Screw 6x25	Skruv 6x25	Schraube 6x25	Vis 6x25
906963	O-ring 23.53x1.78	O-ring 23,53x1,78	O-Ring 23,53x1,78	Joint torique 23,53x1,78
907586	Spring	Fjäder	Feder	Ressort
F1533	Pin 4x10	Pin 4x10	Stift 4x10	Goupille 4x10



DESCRIPTION

The Grease Meter measures the grease quantity that passes through the meter.

The grease quantity dispensed can be shown in cm^3 , gram, oz or fl oz.

The Grease Meter can be calibrated and is equipped with bias lighting for use in dark working environments.

The Grease Meter can also be used to continuously monitor the grease that passes through the meter.

DATA

Max pressure	700 bar
Flow range	0 - 1000 cm^3/min
Accuracy	+/- 3% up to 300 bar
Media	grease NLGI 1-2

HOW TO USE

To start the Grease Meter press the start button:



The display lights up:



The meter is shut off by pressing the left button for 2 seconds.



START/STOP button.

If the Grease Meter is not used, it automatically shuts off after a set time.

The Grease Meter does not measure any grease after auto shut off until it is started again.

To reset the Grease Meter after each dispensing press the



button. (The RESET text shows that in this menu the left button has the reset function.)

To light up the display when working in dark environments press the



button. The light will automatically switch off 5 seconds after the grease flow has stopped.

The battery symbol indicates how much power is left in the batteries.



TOTAL COUNTER 1

The meter is equipped with a total counter which displays the same unit that is used for normal measuring. This total counter is called SUBTO and is a complement to the other total counter that uses the unit TON.

To enter the menu press the



and buttons simultaneously. The display will show:



Press ENTER (left button): the display will show:



This tells you the total amount of grease that has passed the meter since it was reset last time.

To reset the total counter, press ZERO (right button). To exit the menu without resetting the counter, press EXIT (left button).

TOTAL COUNTER 2

The Grease Meter is equipped with another resettable total counter. This counts up to 9999 tons of grease. To enter the menu press the



and buttons simultaneously. The display will show:



Press NEXT (right button): the display will show:



Press ENTER (the left button): the display will show:



This tells you the total amount of grease that has passed the meter since it was reset last time.

Note that the smallest amount that will show is 1 kg (0.001 TON).

To reset the total amount counter press ZERO (right button). To exit the menu press EXIT (left button).



CALIBRATION OF THE METER

The Grease Meter can be calibrated for different grease types etc.

1. CALCULATE THE CORRECTION FACTOR

Correction factor = real quantity / shown quantity

Example:

The dispensed grease weight is 500 gram

The grease meter shows 485 gram

Correction factor = $500 / 485 = 1.03$

2. CALCULATE THE CALIBRATION FACTOR

The new calibration factor = the old calibration factor x the correction factor

Example:

The old calibration factor is 700

The correction factor is calculated to 1.03

The new calibration factor = $700 \times 1.03 = 721$

3. CHANGE THE CALIBRATION FACTOR OF THE GREASE METER

To enter the menu press the



and buttons simultaneously. The display will show:



Press NEXT (right button): the display will show:



Press NEXT (right button): the display will show:



Press ENTER (left button): the display will show the current calibration factor:



The highlighted digit can be stepped up by pressing STEP (right button)





To highlight the next digit press ENTER (left button)



Continue to press STEP and ENTER to set the correct calibration factor.

When the last digit has been accepted by pressing ENTER the display will show:



Press ENTER (left button) to accept and save the new calibration, or CANCEL (right button) to cancel the changes and return to the old calibration factor.

CHANGE UNITS

The Grease Meter can show the grease amount in four different units; cm^3 , gram, oz, and fl oz.

To enter the menu, press:

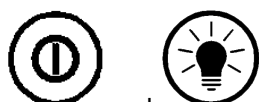

and buttons simultaneously. The display will show:



Press NEXT (right button): the display will show:



Press NEXT (right button): the display will show:



Press NEXT (right button): the display will show:



Press ENTER (left button): the display will show:

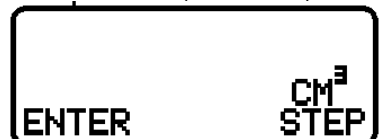

Press STEP (right button) to step to next unit

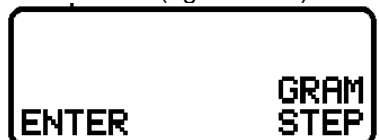

Press ENTER (left button) to accept and save the new unit.



ADJUSTABLE TIME BEFORE AUTOMATIC SHUT OFF

It is possible to choose the time you want the meter to automatically shut off after: (1, 5 or 15 minutes) or whether you want the meter to be in STANDBY mode. In STANDBY mode the display is shut down after one minute; the meter, however, continues to measure all grease that passes through the meter. The batteries provide for 12 months of continuous grease measuring in STANDBY mode.

When the display is shut down in STANDBY mode, it is possible to press:



The display lights up and the amount can be read off. After one minute the display is shut down again.

When the meter is in STANDBY mode, "STBY" is shown on the display.



To enter the menu, press the



and



buttons simultaneously. The display will show:



Press NEXT (right button): the display will show:



Press NEXT (right button): the display will show:



Press NEXT (right button): the display will show:



Press NEXT (right button): the display will show:



Press ENTER (left button): the display will show:



Press STEP (right button) to move forward to the next time or STANDBY mode.



Press ENTER (left button) to accept and save the new time.

EXIT MENU

It is always possible to exit the menus and return to normal measuring state by pressing



and



buttons simultaneously.



BESKRIVNING

Fettmätaren mäter fettmängden som passerar genom den.

Fettmängden kan visas i cm^3 , gram, oz eller fl oz.

Fettmätaren kan kalibreras och är utrustad med displaybelysning för användning i mörka omgivningar.

Fettmätaren kan också användas för kontinuerlig fettövervakning.

DATA

Maxtryck	700 bar
Flödesområde	0 - 1000 cm^3/min
Noggrannhet	+/- 3 % upp till 300 bar
Media	fett NLGI 1-2

ANVÄNDNING

För att starta fettmätaren tryck på startknappen:



Displayen tänds:



Mätaren stängs av genom att hålla in den vänstra knappen 2 sekunder.



START/STOPP-knapp

Om inte fettmätaren används, stängs den automatiskt av efter en inställbar tid.

När fettmätaren stängt av sig fungerar inte mätningen förrän fettmätaren startats igen.

För att nollställa mätaren mellan smörjningarna tryck på



knappen. (RESET-texten visar att i denna meny har den vänstra knappen reset funktion.)

För att tända displaybelysningen vid arbete i mörk omgivning tryck på



knappen. Ljuset släcks automatiskt 15 sekunder efter att fettflödet har upphört.

Batterisymbolen visar batteriernas kapacitet.



TOTALRÄKNEVERK 1

Mätaren är utrustad med ett totalräkneverk som använder samma enhet som vid vanlig mätning. Detta totalräkneverk kallas SUBTO och är ett komplement till det andra totalräkneverket som använder enheten TON.

För att komma in i menyn tryck:



och

knappen samtidigt. Displayen visar:



Tryck ENTER (den vänstra knappen): displayen visar:



Nu visas hur mycket fett som passerat mätaren sedan förra nollställningen.

För att nollställa totalräkneverket tryck ZERO (den högra knappen). För att gå ur menyn utan att nollställa tryck EXIT (den vänstra knappen).

TOTALRÄKNEVERK 2

Fettmätaren är utrustad med ytterligare ett nollställbart totalräkneverk. Detta mäter upp till 9999 ton fett. För att komma in i menyn tryck:



och

knappen samtidigt. Displayen visar:



Tryck NEXT (den högra knappen): displayen visar:



Tryck ENTER (den vänstra knappen): displayen visar:

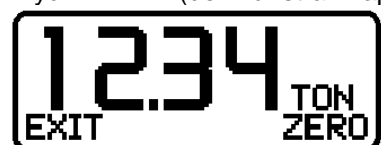

Nu visas hur mycket fett som passerat mätaren sedan förra nollställningen.

Den minsta mängd som kan visas är 1 kg. (0,001 TON).

För att nollställa totalräkneverket tryck ZERO (den högra knappen). För att gå ur menyn utan att nollställa tryck EXIT (den vänstra knappen).



KALIBRERING AV MÄTAREN

Fettmätaren kan kalibreras för olika fettkvaliteter etc.

1. RÄKNA UT FELFAKTORN

Felfaktorn = verklig mängd / visad mängd

Exempel:

Det utmatade fettet väger 500 gram

Fettmätaren visar 485 gram

Felfaktorn = $500 / 485 = 1,03$

2. RÄKNA UT KALIBRERINGSTALET

Det nya kalibreringstalet = det gamla kalibreringstalet x felfaktorn

Exempel:

Det gamla kalibreringstalet är 700

Felfaktorn har räknats fram till 1,03

Det nya kalibreringstalet = $700 \times 1,03 = 721$

3. ÄNDRA KALIBRERINGSTALET I FETTMÄTAREN

För att komma in i menyn tryck



och



knappen samtidigt. Displayen visar:



Tryck NEXT (den högra knappen): displayen visar:



Tryck NEXT (den högra knappen): displayen visar:



Tryck ENTER (den vänstra knappen): displayen visar aktuellt kalibreringstal:



Den markerade siffran kan stegas upp genom att trycka STEP (den högra knappen)





För att markera nästa siffra tryck ENTER (den vänstra knappen)



Fortsätt med att trycka STEP och ENTER för att ställa in det önskade kalibreringstalet.

När den sista siffran har accepterats genom att trycka ENTER visar displayen:



Tryck ENTER (den vänstra knappen) för att acceptera och spara det nya kalibreringstalet, eller CANCEL (den högra knappen) för att ångra ändringarna och återgå till det gamla kalibreringstalet.

ÄNDRA ENHET

Fettmätaren kan visa fettmängden i fyra olika enheter; cm³, gram, oz, and fl oz.
För att komma in i menyn tryck:



och

knappen samtidigt. Displayen visar:



Tryck NEXT (den högra knappen): displayen visar:



Tryck NEXT (den högra knappen): displayen visar:



Tryck NEXT (den högra knappen): displayen visar:



Tryck ENTER (den vänstra knappen): displayen visar:



Tryck STEP (den högra knappen) för att stega fram nästa enhet



Tryck ENTER (den vänstra knappen) för att acceptera och spara den nya enheten.



JUSTERBAR TID FÖRE AUTOMATISK AVSTÄNGNING

Det är möjligt att välja efter vilken tid fettmätaren automatiskt stängs av. 1, 5 eller 15 minuter. Det är också möjligt att ställa mätaren i STAND BY läge. I STAND BY läget släcks displayen ned efter en minut, mätaren fortsätter dock att mäta allt fett som passerar genom mätaren. Batterierna räcker i 12 månader för kontinuerlig fettmätning i STAND BY läge.

När displayen har släckts ned i STAND BY läge kan man trycka:



Displayen tänds då upp och mängden kan avläsas. Efter en minut släcks displayen åter ned.

När mätaren är i STAND BY läge, visas STBY i displayen.



För att komma in i menyn tryck:



och



knappen samtidigt. Displayen visar:



Tryck NEXT (den högra knappen): displayen visar:



Tryck NEXT (den högra knappen): displayen visar:



Tryck NEXT (den högra knappen): displayen visar:



Tryck NEXT (den högra knappen): displayen visar:



Tryck ENTER (den vänstra knappen): displayen visar:



Tryck STEP (den högra knappen) för att stega fram till nästa tid eller STAND BY läge.



Tryck ENTER (den vänstra knappen) för att acceptera och spara den nya tiden.

GÅ UR MENYERNA

Det är alltid möjligt att gå ur menyerna och återvända till normal mätning genom att trycka:



och



knappen samtidigt.



BESCHREIBUNG

Der Fettmesser misst die durch das Gerät laufende Fettmenge.
Die Fettmenge kann in cm^3 , Gramm, oz oder fl oz angezeigt werden.
Der Fettmesser lässt sich kalibrieren, und das Display ist beleuchtet, so dass auch in dunkler Umgebung problemlos gemessen werden kann.
Der Fettmesser kann zudem zur kontinuierlichen Fettüberwachung verwendet werden.

DATEN

Höchstdruck	700 bar
Durchflussmenge	0 - 1000 cm^3/min
Präzision	+/- 3 % bis 300 bar
Medium	Fett NLGI 1-2

BEDIENUNG

Zum Starten des Fettmessers auf den Startknopf drücken:



Das Display leuchtet:



Der Fettmesser wird abgeschaltet, indem der linke Knopf 2 sek lang gedrückt wird.



START/STOPP-Knopf

Bei Nichtbenutzung des Fettmessers schaltet dieser sich nach einer einstellbaren Zeit automatisch ab. Wenn sich der Fettmesser abgestellt hat, kann erst wieder gemessen werden, wenn das Gerät wieder angestellt wird.

Zur Nullstellung des Messgerätes zwischen den Schmierungen auf



drücken. (Der RESET-Text gibt an, dass bei diesem Menü der linke Knopf die Reset-Funktion hat.)

Zum Einschalten der Displaybeleuchtung bei Arbeiten in dunkler Umgebung auf



drücken. Die Beleuchtung erlischt automatisch 15 Sekunden nach Beendigung des Fettflusses.

Das Batteriesymbol gibt den Ladezustand der Batterien an.



GESAMTZÄHLWERK 1

Der Fettmesser ist mit einem Gesamtzählwerk ausgestattet, das dieselbe Maßeinheit wie beim normalen Messvorgang verwendet. Dieses Gesamtzählwerk wird SUBTO genannt und ist eine Ergänzung des zweiten Gesamtzählwerks, das die Einheit Tonne (TON) verwendet.

Um ins Menü zu gelangen, gleichzeitig auf



und drücken. Auf dem Display erscheint:



ENTER drücken (linker Knopf): Auf dem Display erscheint:



Jetzt wird angegeben, wie viel Fett das Gerät seit der letzten Nullstellung durchlaufen hat.

Zur Nullstellung des Gesamtzählwerks auf ZERO drücken (rechter Knopf). Zum Verlassen des Menüs ohne Nullstellung auf EXIT drücken (linker Knopf).

GESAMTZÄHLWERK 2

Der Fettmesser ist mit einem weiteren nullstellbaren Gesamtzählwerk ausgestattet. Dieses misst bis zu 9999 t Fett.

Um ins Menü zu gelangen, gleichzeitig auf



und drücken. Auf dem Display erscheint:



NEXT drücken (rechter Knopf): Auf dem Display erscheint:



ENTER drücken (linker Knopf): Auf dem Display erscheint:



Jetzt wird angegeben, wie viel Fett das Gerät seit der letzten Nullstellung durchlaufen hat.

Die kleinste anzeigbare Menge beträgt 1 kg (0,001 t).

Zur Nullstellung des Gesamtzählwerks auf ZERO drücken (rechter Knopf). Zum Verlassen des Menüs ohne Nullstellung auf EXIT drücken (linker Knopf).



KALIBRIERUNG DES MESSGERÄTES

Der Fettmesser lässt sich für verschiedene Fettqualitäten usw. kalibrieren.

1. BERECHNUNG DES FEHLERFAKTORS

Fehlerfaktor = tatsächliche Menge/angezeigte Menge

Beispiel:

Das durchgeströmte Fett wiegt 500 g.

Der Fettmesser zeigt 485 g.

Fehlerfaktor = $500 / 485 = 1,03$

2. BERECHNUNG DES KALIBRIERWERTES

Der neue Kalibrierwert = der alte Kalibrierwert x Fehlerfaktor

Beispiel:

Der alte Kalibrierwert beträgt 700.

Der Fehlerfaktor wurde mit 1,03 ermittelt.

Der neue Kalibrierwert = $700 \times 1,03 = 721$

3. ÄNDERUNG DES KALIBRIERWERTES IM FETTMESSER

Um ins Menü zu gelangen, gleichzeitig auf



und



drücken. Auf dem Display erscheint:



NEXT drücken (rechter Knopf): Auf dem Display erscheint:



NEXT drücken (rechter Knopf): Auf dem Display erscheint:



ENTER drücken (linker Knopf): Das Display zeigt den aktuellen Kalibrierwert:



Die markierte Ziffer kann durch Drücken von STEP (rechter Knopf) erhöht werden.





Zur Markierung der nächsten Ziffer auf ENTER drücken (linker Knopf).



Weiter auf STEP und ENTER drücken und so den gewünschten Kalibrierwert einstellen.

Sobald die letzte Ziffer mit ENTER bestätigt wurde, zeigt das Display:



ENTER drücken (linker Knopf) und den neuen Kalibrierwert bestätigen und speichern, oder CANCEL (rechter Knopf) und die Änderungen rückgängig machen und zum alten Wert zurückkehren.

ÄNDERUNG DER MAßEINHEIT

Der Fettmesser kann die Fettmenge in vier Maßeinheiten anzeigen: cm³, Gramm, oz, und fl oz.
Um ins Menü zu gelangen, gleichzeitig auf



und drücken. Auf dem Display erscheint:



NEXT drücken (rechter Knopf): Auf dem Display erscheint:



NEXT drücken (rechter Knopf): Auf dem Display erscheint:



NEXT drücken (rechter Knopf): Auf dem Display erscheint:



ENTER drücken (linker Knopf): Auf dem Display erscheint:



STEP drücken (rechter Knopf) und bis zur nächsten Maßeinheit gehen.



ENTER betätigen (linker Knopf) und die neue Maßeinheit bestätigen und speichern.



EINSTELLBARE ZEIT VOR DEM AUTOMATISCHEN ABSCHALTEN

Die Zeit, nach der sich der Fettmesser automatisch abschaltet, ist wählbar: nach 1, 5 oder 15 min. Darüber hinaus ist es möglich, das Messgerät in den STANDBY-Modus zu versetzen. Im STANDBY-Modus erlischt das Display nach einer Minute, das Messgerät misst jedoch weiterhin das gesamte durchlaufende Fett. Die Batterien haben eine Lebensdauer von 12 Monaten, wenn im STANDBY-Modus kontinuierlich gemessen wird.

Bei erloschenem Display im STANDBY-Modus kann folgender Knopf gedrückt werden:



Das Display leuchtet dann auf und die Menge kann abgelesen werden. Nach einer Minute erlischt das Display wieder.

Wenn sich der Fettmesser im STANDBY-Modus befindet, wird STBY im Display angezeigt.



Um ins Menü zu gelangen, gleichzeitig auf



und



drücken. Auf dem Display erscheint:



NEXT drücken (rechter Knopf): Auf dem Display erscheint:



NEXT drücken (rechter Knopf): Auf dem Display erscheint:



NEXT drücken (rechter Knopf): Auf dem Display erscheint:



NEXT drücken (rechter Knopf): Auf dem Display erscheint:



ENTER drücken (linker Knopf): Auf dem Display erscheint:



STEP drücken (rechter Knopf) und bis zur nächsten Zeit oder in den STANDBY-Modus gehen.



ENTER betätigen (linker Knopf) und die neue Zeit bestätigen und speichern.

MENÜS VERLASSEN

Man kann die Menüs jederzeit verlassen und wieder zur Normalmessung zurückgehen, dazu gleichzeitig



und



drücken.

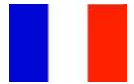

DESCRIPTION

Le mesureur de graisse mesure la quantité de graisse qui le traverse.

La quantité de graisse est affichée en cm^3 , grammes, oz ou fl oz.

Le mesureur de graisse peut être étalonné et équipé d'un éclairage d'écran pour être utilisé dans des conditions de faible luminosité.

Le mesureur de graisse peut également être utilisé pour la surveillance continue de la graisse.

CARACTÉRISTIQUES

Pression max.	700 bar
Plage de débit	0 - 1000 cm^3/min
Précision	+/- 3% jusqu'à 300 bar
Agent	graisse NLGI 1-2

UTILISATION

Pour démarrer le mesureur de graisse appuyer sur le bouton Marche :



L'écran s'allume :



Pour éteindre le mesureur de graisse, maintenir le bouton gauche enfoncé pendant 2 secondes.



Bouton MARCHE/ARRÊT

Si le mesureur de graisse n'est pas utilisé, il s'éteint automatiquement au bout d'un délai réglable. Lorsque le mesureur de graisse s'est éteint, la mesure ne fonctionne pas avant qu'il soit redémarré.

Pour remettre à zéro l'appareil entre les lubrifications appuyer sur le bouton



. (Le texte RESET indique que dans ce menu le bouton gauche a la fonction de remise à zéro.)

Pour allumer l'éclairage de l'écran en cas de travail dans des conditions de faible luminosité appuyer sur le bouton



. La lumière s'éteint automatiquement 15 secondes après l'arrêt du débit de graisse.

Le symbole de la batterie indique la capacité de la batterie.

COMPTEUR TOTAL 1

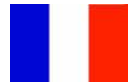

Le mesureur de graisse est équipé d'un compteur total utilisant la même unité que pour la mesure ordinaire. Ce compteur total est appelé SUBTO et complète l'autre compteur total qui utilise l'unité TONNE

Pour entrer dans le menu appuyer sur



et simultanément. L'écran affiche :



Appuyer sur ENTER (le bouton de gauche) : l'écran affiche :



L'écran affiche la quantité de graisse qui a traversé le mesureur depuis la dernière remise à zéro.

Pour remettre à zéro le compteur total, appuyer sur ZERO (le bouton de droite). Pour sortir du menu sans remettre à zéro appuyer sur EXIT (le bouton de gauche).

COMPTEUR TOTAL 2

Le mesureur de graisse est équipé d'un deuxième compteur total pouvant être remis à zéro. Ce compteur mesure jusqu'à 9999 tonnes de graisse. Pour entrer dans le menu appuyer sur les boutons



et simultanément. L'écran affiche :



Appuyer sur NEXT (le bouton de droite), l'écran affiche :



Appuyer sur ENTER (le bouton de gauche), l'écran affiche :



L'écran affiche la quantité de graisse qui a traversé le mesureur depuis la dernière remise à zéro.

La quantité minimale qui peut être affichée est de 1 kg. (0,001 TONNE).

Pour remettre à zéro le compteur total, appuyer sur ZERO (le bouton de droite). Pour sortir du menu sans remettre à zéro appuyer sur EXIT (le bouton de gauche).

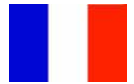

ÉTALONNAGE DU MESUREUR

Le mesureur de graisse peut être étalonné pour différentes qualités de graisse, etc.

1. CALCULER LE FACTEUR D'ERREUR

Facteur d'erreur = quantité réelle / quantité affichée

Exemple :

La quantité de graisse évacuée pèse 500 grammes
Le mesureur de graisse indique 485 grammes

Facteur d'erreur = $500 / 485 = 1,03$

2. CALCULER LA VALEUR D'ÉTALONNAGE

La nouvelle valeur d'étalonnage = l'ancienne valeur d'étalonnage x le facteur d'erreur

Exemple :

L'ancienne valeur d'étalonnage est de 700
Le facteur d'erreur calculé est de 1,03

La nouvelle valeur d'étalonnage = $700 \times 1,03 = 721$

3. MODIFIER LA VALEUR D'ÉTALONNAGE DANS LE MESUREUR DE GRAISSE

Pour entrer dans le menu appuyer sur



et



simultanément. L'écran affiche :



Appuyer sur NEXT (le bouton de droite) : l'écran affiche :



Appuyer sur NEXT (le bouton de droite) : l'écran affiche :



Appuyer sur ENTER (le bouton de gauche) : l'écran affiche la valeur d'étalonnage :



On peut augmenter le chiffre marqué en appuyant sur STEP (le bouton de droite) :



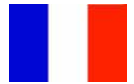

Pour marquer le chiffre suivant appuyer sur ENTER (le bouton de gauche) :



Continuer en appuyant sur STEP et ENTER pour paramétrer la valeur d'étalonnage souhaitée.

Lorsque le dernier chiffre a été approuvé par une pression sur ENTER, l'écran affiche :



Appuyer sur ENTER (le bouton de gauche) pour approuver et sauvegarder la nouvelle valeur d'étalonnage ou sur CANCEL (le bouton de droite) pour annuler les modifications et revenir à l'ancienne valeur d'étalonnage.

MODIFIER L'UNITÉ

Le mesureur de graisse peut afficher la quantité de graisse en quatre unités différentes : cm³, grammes, oz, et fl oz. Pour entrer dans le menu appuyer sur :



et simultanément. L'écran affiche :



Appuyer sur NEXT (le bouton de droite) : l'écran affiche :



Appuyer sur NEXT (le bouton de droite) : l'écran affiche :



Appuyer sur NEXT (le bouton de droite) : l'écran affiche :



Appuyer sur ENTER (le bouton de gauche) : l'écran affiche :



Appuyer sur STEP (le bouton de droite) pour afficher l'unité suivante :

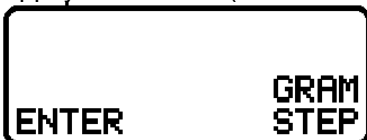

Appuyer sur ENTER (le bouton de gauche) pour approuver et sauvegarder la nouvelle unité.

DÉLAI RÉGLABLE AVANT L'ARRÊT AUTOMATIQUE



Il est possible de choisir le délai au bout duquel le mesureur de graisse s'éteint automatiquement. 1, 5 ou 15 minutes. Il est également possible de placer le mesureur en mode STAND BY. En mode STAND BY, l'écran s'éteint au bout d'une minute, mais le mesureur continue à mesurer toute la graisse qui le traverse. Les batteries présentent une autonomie d'12 mois en cas de mesure de graisse continue en mode STAND BY.

Lorsque l'écran s'est éteint en mode STAND BY, appuyer sur



pour rallumer l'écran et lire la quantité affichée. L'écran s'éteint à nouveau au bout d'une minute.

Lorsque le mesureur est en mode STAND BY, l'écran indique STBY.



Pour entrer dans le menu appuyer sur les boutons



et

simultanément. L'écran affiche



Appuyer sur NEXT (le bouton de droite), l'écran affiche :



Appuyer sur NEXT (le bouton de droite), l'écran affiche :



Appuyer sur NEXT (le bouton de droite), l'écran affiche :



Appuyer sur NEXT (le bouton de droite), l'écran affiche :



Appuyer sur ENTER (le bouton de gauche), l'écran affiche :



Appuyer sur STEP (le bouton de droite) pour passer au délai suivant ou en mode STAND BY.

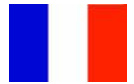

Appuyer sur ENTER (le bouton de gauche) pour accepter et enregistrer le nouveau délai.

SORTIR DES MENUS

Il est toujours possible de sortir des menus et de retourner à la mesure normale en appuyant sur



et



simultanément.

MENU STRUCTURE MENÜAUFBAU

MENYUPPBYGGNAD STRUCTURE DES MENUS

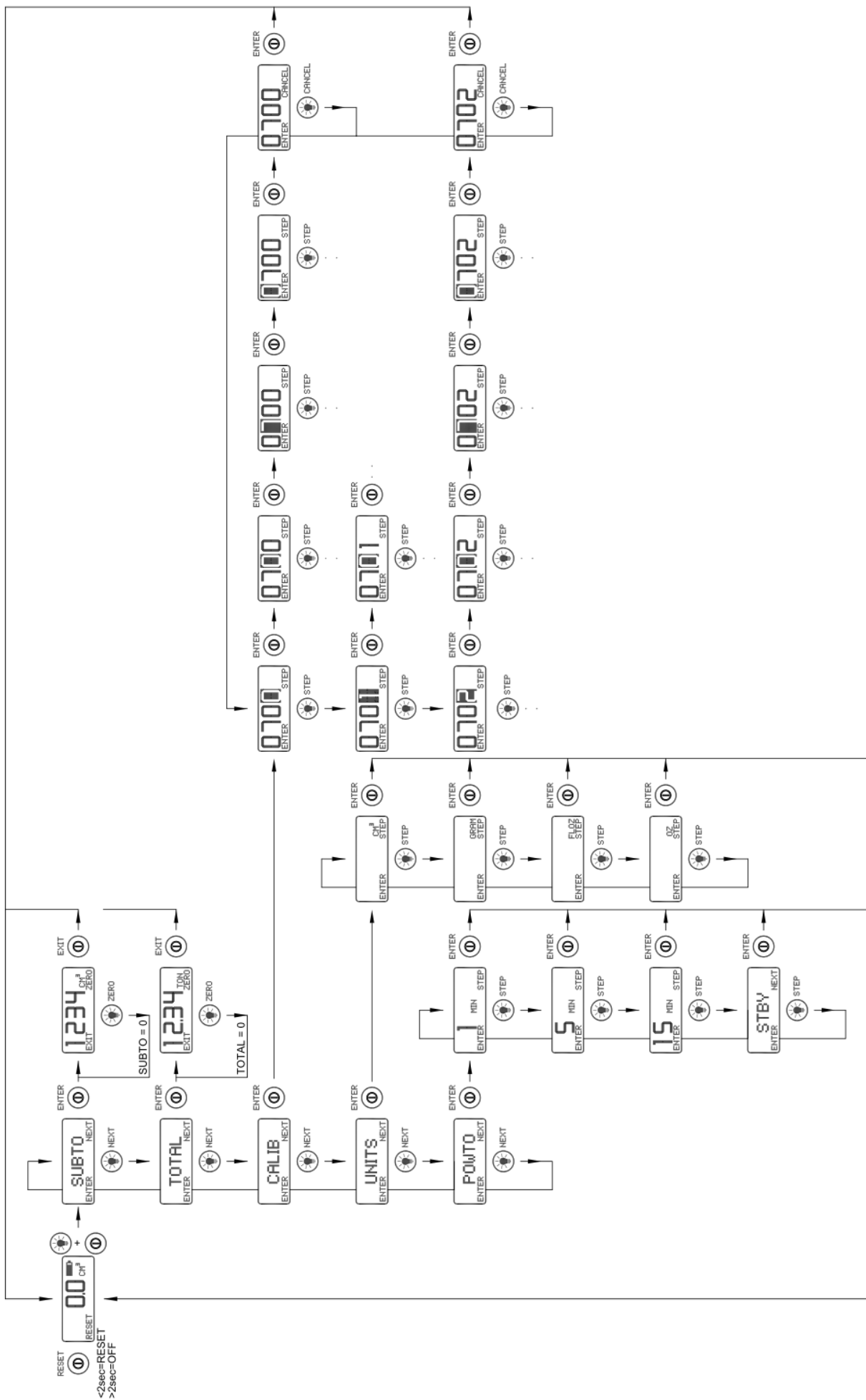

EU DECLARATION OF CONFORMITY

We, Assalub AB,
Prästängsvägen 15, SE-597 30 Åtvidaberg, Sweden,
declare that the

GREASE METER MKIII

Art. Nos. 0102525, 0102525-1, 0102525-2

is designed and manufactured in accordance with

EUROPEAN EMC DIRECTIVE 2004/108/EC

as outlined in the harmonized Norms

EN 61000-6-3:2007

EN 61000-6-2:2005

EN 61000-4-2, -3, -8

Åtvidaberg, May 23, 2014



Niklas Rehn
Manager Product Development and Quality